



Aldon Company, Inc. | 3410 Sunset Avenue | Waukegan, IL 60087
PH. 847.623.8800 | FX. 847.623.6139 | www.aldonco.com | e-rail@aldonco.com

TRACK PAN QUESTIONNAIRE

For Part Numbers 4130-02, 03, 04, 05, 06, 07, 08, 09, 10, 11, 12

Company _____

Date _____

Contact _____

PO Number _____

Phone _____

Fax _____

Email _____

Order # (If you've already ordered) _____

HEIGHT "A" _____

TIES (Please Circle One)

WOOD CONCRETE STEEL

HEIGHT "B" _____

TRACK ATTACHMENT (Please Circle One)

SPIKES BOLTS PANDROL

(Please fill out form on page 2 if you have chosen pandrol.)

TRACK CURVED (Please Circle One)

YES NO

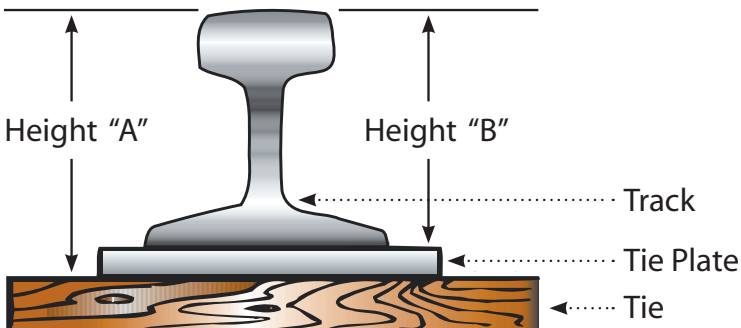

Information Received From _____

Date _____

Return this form with the upload option when you order OR use the submit button above OR fax to (847) 623-6139.

This is a Custom Order | Non-Returnable | Non-Refundable

How much containment is needed?

How long of a system will be needed?

Is this one system, or is this more than one system? (If more than one, how many?)

Will drains be installed?

Will the end user drive over the pans?

When is the planned or target installation date?

What is the substrate?

What chemical/s need to be contained?

Is the temperature of the substance being contained warmer than ambient temperature?

Is there a curve to the rail where the pans will be installed?

WIDTH
"X"

WIDTH
"Y"

WIDTH
"Z"

WIDTH "Y" SHOULD BE MEASURED BETWEEN THE TRACK
RAIL WEB-TO-WEB.

WIDTH "Z" SHOULD BE MEASURED BETWEEN ANY
OBSTRUCTIONS BETWEEN THE TRACKS, I.E., SPLICE PLATES
AND HARDWARE.

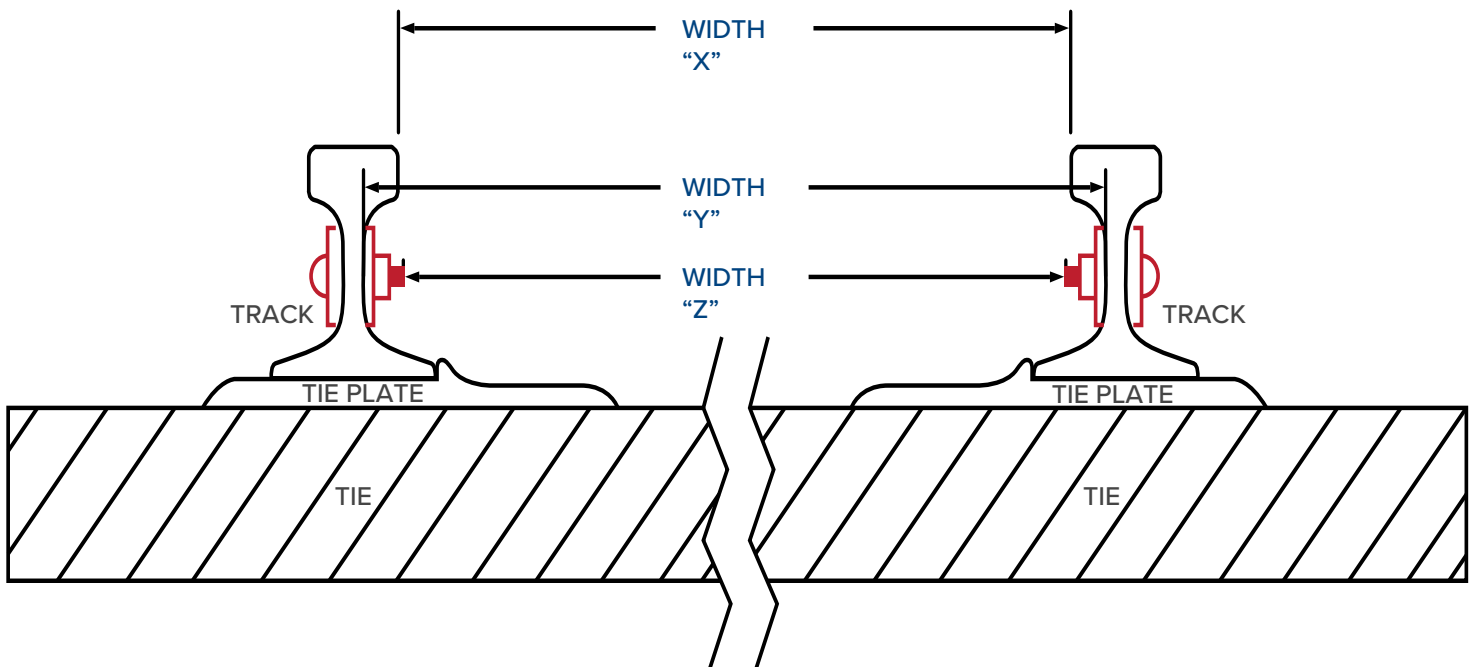

PANDROL WORKSHEET

DRAWING & MEASUREMENTS:

IMPORTANT:

Dimension "B" must have 5-1/4" to 5-1/2" clearance above pandrol clips for center pan clearance.

Do NOT fill out this form unless you have pandrols.

