

**DETAIL "A"**

**NOTES:**

1. SIGN TO BE NO. 3870 SILVER 3M HIGH INTENSITY BACKGROUND WITH 2" DIAGONAL ORANGE CANDY STRIPES ON 0.080" 3105 SHEET ALUMINUM OR EQUIVALENT.
2. HOLE SIZES FOR FLANGED CHANNEL POST ARE PRE DRILLED 3/8" DIA. FOR 5/16" X 1 1/4" ZINC PLATED BOLTS.
3. 48 HRS. BEFORE BEGINNING ANY DIGGING OPERATIONS, CALL UNION PACIFIC'S CALL BEFORE YOU DIG HOTLINE AT 1-800-336-9193.
4. ON SINGLE MAINLINE TRACK, SIGN TO BE INSTALLED ON MAINLINE SIDE OF SWITCH ADJACENT TO THE CENTER OF THE JUMP FROG. ON MULTIPLE MAINLINE TRACK, SIGN TO BE PLACED ON TURNOUT SIDE OF SWITCH ADJACENT TO THE CENTER OF THE JUMP FROG. SIGN TO BE A MINIMUM OF 10'-0" FROM CENTER OF CLOSEST TRACK WITH OFFSET FACING AWAY FROM TRACK.
5. SIGN TO BE DOUBLE SIDED SO VISIBLE FROM BOTH DIRECTIONS OF TRAVEL ON TRACK.

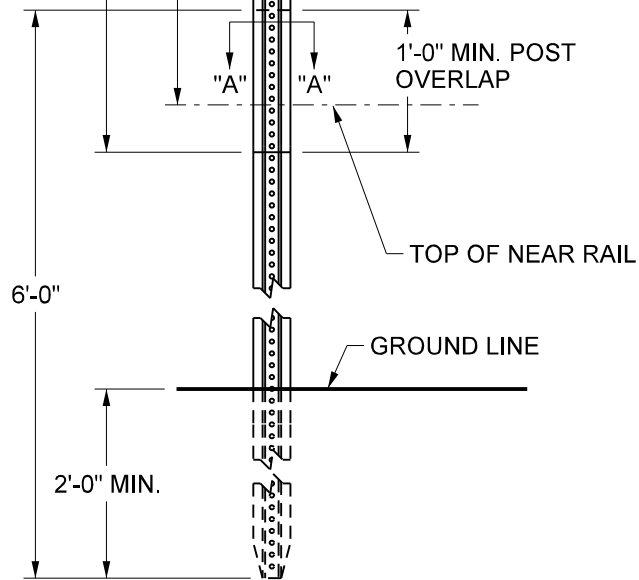

DESCRIPTION	ITEM NO.
JUMP FROG WARNING SIGN	393-1565
6'-0" 2 LB STEEL POST (X2)	393-7510
BOLT PACK FOR JOINT 6'-0" STEEL POSTS	393-7329
BOLT PACK 5/16" x 5" FOR MOUNTING SIGN	393-7299

**UNION PACIFIC RAILROAD  
ENGINEERING STANDARDS**

**JUMP FROG  
WARNING SIGN**



ADOPTED: SEP. 21, 2020  
REVISED:  
FILE NO.: 0547

**STD DWG**

**0547**

**0547**  
**STD DWG**