



Aldon Company, Inc. | 3410 Sunset Avenue | Waukegan, IL 60087
PH. 847.623.8800 | FX. 847.623.6139 | www.aldonco.com | e-rail@aldonco.com

TRACK PAN QUESTIONNAIRE

For Part Numbers 4130-02, 03, 04, 05, 06, 07, 08, 09, 10, 11, 12

Company _____

Date _____

Contact _____

PO Number _____

Phone _____

Fax _____

Email _____

Order # (If you've already ordered) _____

HEIGHT "A" _____

TIES (Please Circle One)

WOOD CONCRETE STEEL

HEIGHT "B" _____

TRACK ATTACHMENT (Please Circle One)

SPIKES BOLTS PANDROL

(Please fill out form on page 2 if you have chosen pandrol.)

TRACK CURVED (Please Circle One)

YES NO

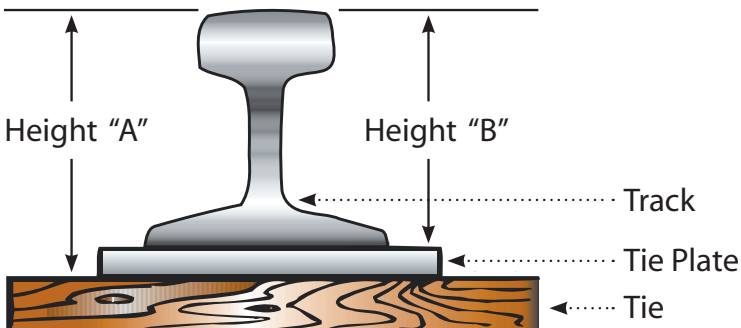

Information Received From _____

Date _____

Return this form with the upload option when you order OR use the submit button above OR fax to (847) 623-6139.

This is a Custom Order | Non-Returnable | Non-Refundable

PANDROL WORKSHEET

DRAWING & MEASUREMENTS:

IMPORTANT:

Dimension "B" must have 5-1/4" to 5-1/2" clearance above pandrol clips for center pan clearance.

Do NOT fill out this form unless you have pandrols.

