



Aldon Company, Inc. | 3410 Sunset Avenue | Waukegan, Illinois 60087

PH. 847.623.8800 | FX. 847.623.6139 | e-rail@aldonco.com | www.aldonco.com

Firm: _____ Date: _____

Attn: _____ Your Phone: _____

Your P.O.: _____ Order #: _____ Your Fax: _____
If you've already ordered.

Your Email: _____ No. Pages.: _____ including this page

RAIL CAR STABILIZER SIZING FORM

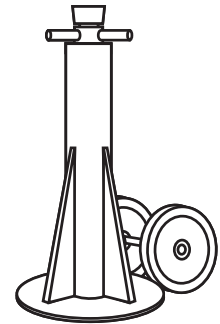
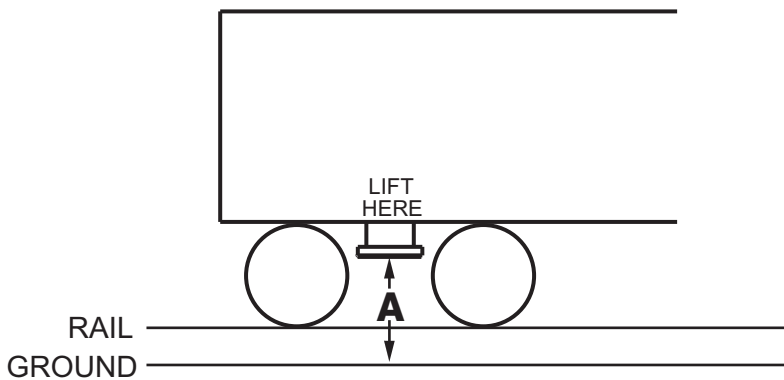

4013-01-S
Spin Top Screw

1. Measure height from ground to underside of Jacking point ("A") near each end of railcar.

("A"): _____"

2. If you work with different car body heights, please note additional different "A" heights:

_____ " _____ " _____ " _____ "

**For proper support
(4) jacks are needed
per car.**

**Install at designated
lifting / jacking pads
on car.**

Maximum Jack Height: 54". (with screw fully extended)

Maximum Screw Elevation 6"

3. FAX form to **847.623.6139** or email or upload to AldonCo.com

4. We will prepare a drawing for your approval before starting your order.

SIGNATURE

DATE

This is a special order item and cannot be returned.

rev. 2019-08-30