

# INSTRUCTIONS

## for installing ALDON® ONE-WAY HINGED DERAIL on wood ties

### Manual Lift Sign Holder

#### LEFT THROW

- 4014-01-5L  
size 5-left
- 4014-01-6L  
size 6-left
- 4014-01-7L  
size 7-left
- 4014-01-8L  
size 8-left



### Manual Lift Sign Holder

#### RIGHT THROW

- 4014-02-5R  
size 5-right
- 4014-02-6R  
size 6-right
- 4014-02-7R  
size 7-right
- 4014-02-8R  
size 8-right

### Pop-Up Sign Holder

#### LEFT THROW

- 4014-10-5L  
size 5-left
- 4014-10-6L  
size 6-left
- 4014-10-7L  
size 7-left
- 4014-10-8L  
size 8-left

#### Left Throw

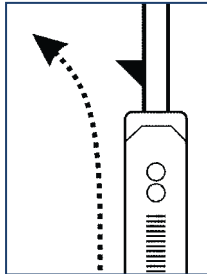

#### Right Throw

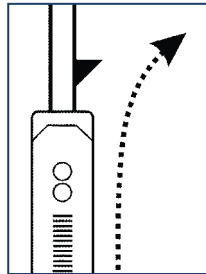

### Pop-Up Sign Holder

#### RIGHT THROW

- 4014-12-5R  
size 5-right
- 4014-12-6R  
size 6-right
- 4014-12-7R  
size 7-right
- 4014-12-8R  
size 8-right



**ALDON®**

Safety on Track Since 1904

Aldon Company, Inc. | 3410 Sunset Avenue | Waukegan, Illinois 60087

PH. 847.623.8800 | FX. 847.623.6139

www.aldonco.com | e-rail@aldonco.com

## IMPORTANT INFORMATION ABOUT DERAILS

Derails help prevent unauthorized movement of railcars and protect sidings from unexpected intrusion by other rolling stock or engines. The derail lifts the flange of the wheel high enough to drop it off the rail and onto the ties. Simultaneously, the wheel opposite the derail is guided off its rail. Once the wheels leave the rails, forward movement is greatly impeded.

### ONE-WAY DERAILS HELP PREVENT THESE TYPES OF SPUR TRACK ACCIDENTS:

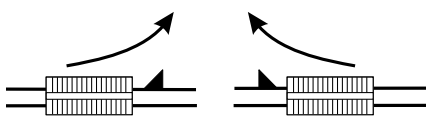

One car rolling into another.

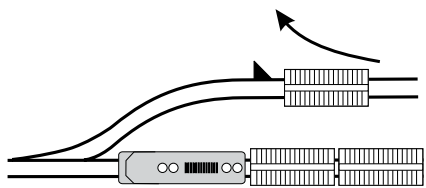

A loose car rolling out to the mainline.

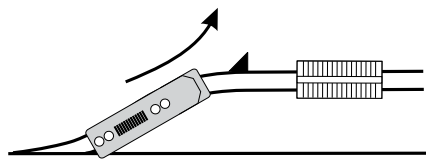

Unauthorized locomotive coupling to stationary car.

One-way derails are designed to derail freight cars and locomotives.

### Effective derailing depends on:

1. Proper derail size and installation.
2. Normal switching speeds. 10 m.p.h. or less.
3. Fully exposed track: ties and ballast absorb impact of derailed wheels and help bring the car or locomotive to a stop. If you have flush rail, contact Aldon for guidance on installing and using a derail.
4. Rail condition must be #1 relay or better. Install on sound wooden ties. Do not install on resin or concrete ties. For steel ties, see Aldon Base Plate Accessory: 4014-13.
5. Leave ample room off-track for the derailed car or locomotive to come to a stop.
6. In curved track, install the derail on the outer rail, not the inner rail. See page 3 (Curved Track) for more details.

## 2 One-Way Hinged Derail Instructions

# INSTALLATION

## LOCATION OF DERAIL

Choose a place where there is ample room off-track for a derailed car to roll into the ballast and dirt. Do not install derails near buildings, roadways, or other vulnerable objects. Depending on speed, a derailed car may slide 50 or more feet before coming to a stop.

**Derailed Direction:** Two-way derails throw the rail car to the field side of the rail on which the derail is positioned.

Note that “left” or “right” is from the viewpoint of the railcar going down the track.

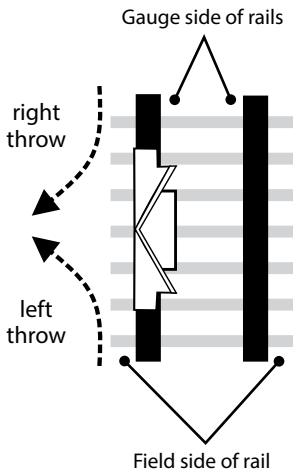

## TRACK CONDITION

Install derail where rails are #1 relay quality or better (less than 1/8' head wear).

Rail size must be appropriate to derail size you have ordered. (see explanation on page 5)

Ties must be of sound wood. Use screw spikes (supplied with derail) to ensure proper anchoring.

## CURVED TRACK

In curved track, for more assured derailing, always install the derail on the **outer** curved rail. Wheels naturally hug the outer rail as they round into the curve, and thus are more likely to climb over the rail and down to the ballast. Conversely, wheels tend to draw away from the inner curved rail on entering the curve, thus reducing the likelihood that a derail installed on the inner rail will carry the wheel over the rail.

In certain situations, due to lack of open ground off-track, it may be necessary to install the derail on the inner curved rail.

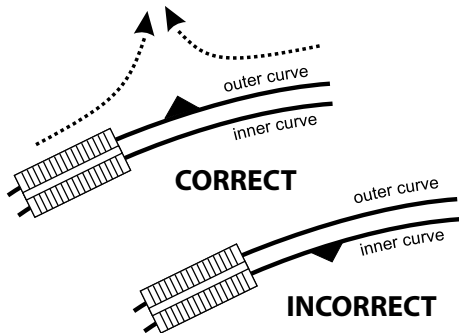

# INSTALLATION

## CORRECT DERAIL SIZE

Before installing, it is always wise to make sure you have the correct derail size for your rail. The height of the rail above the tie is the critical measurement for sizing a derail. Hinged derails are made in four size ranges (5, 6, 7, 8), each of which fits rail heights over a 7/8" range. When measuring height of rail, use a straight-edge laid across both rails to establish a horizontal line.

### Your measurement of rail height must include the tie plate.

The tie plate remains in place during derail installation, but the inside (gauge) edge of the plate will have to be cropped to allow the derail to seat properly.

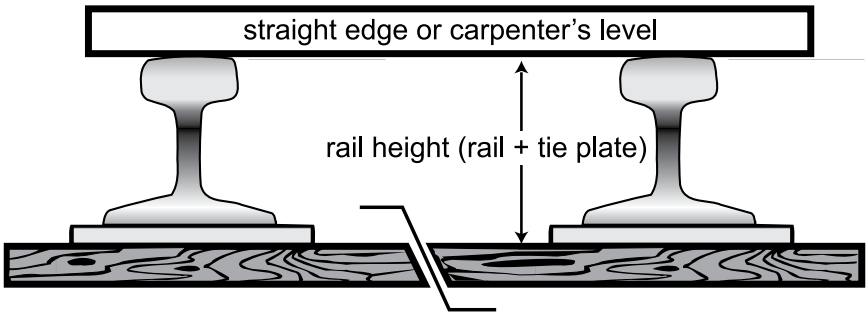

**NOTE:** Make sure there is no gap between rail, tie plate, and tie. Any such "daylight" must be removed by lifting the tie and re-tamping.

**CAUTION:** Some derail installations will require shimming up the derail to equal height of the rail. Shims should be steel plate, equal in size to the derail base flange, and through-bolted in order to properly secure the derail to ties. Make-shift shims do not provide a solid foundation.

# INSTALLATION

## DERAIL SIZE RANGES

note that "height of rail" includes tie plate thickness

HEIGHT OF RAIL	DERAIL SIZE	HEIGHT OF RAIL	DERAIL SIZE	HEIGHT OF RAIL	DERAIL SIZE	HEIGHT OF RAIL	DERAIL SIZE
4 5/8" .....	5	5 5/8" .....	6	6 5/8" .....	7	7 5/8" .....	8
4 3/4" .....	5	5 3/4" .....	6	6 3/4" .....	7	7 3/4" .....	8
4 7/8" .....	5	5 7/8" .....	6	6 7/8" .....	7	7 7/8" .....	8
5" .....	5	6" .....	6	7" .....	7	8" .....	8
5 1/8" .....	5	6 1/8" .....	6	7 1/8" .....	7	8 1/8" .....	8
5 1/4" .....	5	6 1/4" .....	6	7 1/4" .....	7	8 1/4" .....	8
5 3/8" .....	5	6 3/8" .....	6	7 3/8" .....	7		
5 1/2" .....	5	6 1/2" .....	6	7 1/2" .....	7		

*Note that notching of tie or shimming of derail will be needed in most cases to insure an accurate fit.*

## PREPARE THE TRACK

1. Bring two ties together so they are 12" apart on inside faces.
2. Dig out enough gravel in order to seat the derail down on the two ties.
3. Cut the gauge-side of the tie plates on the two ties in question even with the base of the rail. (If not trimmed, the tie plate will interfere with seating the derail.)

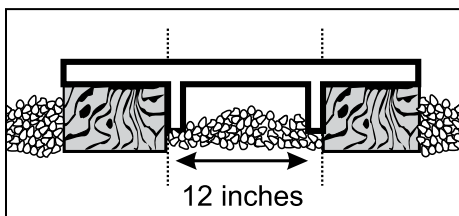

**Never leave any gap between the rail and tie.** Any such gap will create an insecure foundation for the derail.

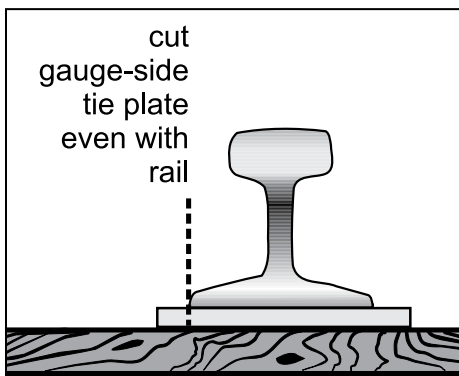

# INSTALLATION

## POSITIONING THE DERAIL

Place the derail on the two ties, so the derail block lies flat on top of the rail. Push the derail against the rail until the curved ends of the derail block support arms touch the rail head.

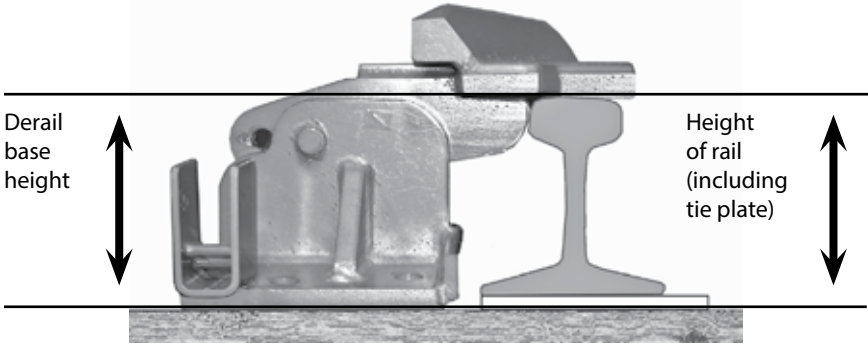

## NOTCHING OR SHIMMING TO INSURE A PROPER FIT

Because each of the four derail sizes (5, 6, 7, 8) covers a range of rail heights, most derails will need to be lifted or lowered from 1/8" to 1/2" in order to make the derail base height exactly equal to the height-of-rail.

Lifting or lowering the derail is accomplished by shimming the derail or notching into the ties. The chart on the top of page 7 notes the exact amount of shimming or notching needed for each 1/8" difference in derail base height and height-of-rail. **Be exact in notching and shimming the ties.** The maximum notch depth is 3/8"; the maximum shim height is 3/4".

Shims should be steel plate equal in size to derail base flange, and through-bolted in order to properly secure derail to ties. Aldon can supply steel shims (see back page).

In some cases, derail base height will be the same as height-of-rail and no lifting or lowering will be necessary.

**(When measuring height of rail round up to the next 1/8")**

## POSITIONING THE DERAIL (final check of derail fit)

Once the shimming or notching work is done, make a "dry fit" of the derail. Be sure that the derail block lies flat on the rail. If you see a gap between the derail block and the top of the rail head, make further shimming or notching adjustments until you eliminate the gap.

# INSTALLATION

Note that "height of rail" includes tie plate thickness

		ADJUSTMENT	
HEIGHT OF RAIL	DERAIL SIZE	NOTCH TIE	SHIM DERAIL
4 5/8"	5	3/8"	
4 3/4"	5	1/4"	
4 7/8"	5	1/8"	
5"	5	-	-
5 1/8"	5		1/8"
5 1/4"	5		1/4"
5 3/8"	5		3/8"
5 1/2"	5		1/2"
5 5/8"	6	3/8"	
5 3/4"	6	1/4"	
5 7/8"	6	1/8"	
6"	6	-	-
6 1/8"	6		1/8"
6 1/4"	6		1/4"
6 3/8"	6		3/8"
6 1/2"	6		1/2"

Note that "height of rail" includes tie plate thickness

		ADJUSTMENT	
HEIGHT OF RAIL	DERAIL SIZE	NOTCH TIE	SHIM DERAIL
6 5/8"	7	3/8"	
6 3/4"	7	1/4"	
6 7/8"	7	1/8"	
7"	7	-	-
7 1/8"	7		1/8"
7 1/4"	7		1/4"
7 3/8"	7		3/8"
7 1/2"	7		1/2"
7 5/8"	8	3/8"	
7 3/4"	8	1/4"	
7 7/8"	8	1/8"	
8"	8	-	-
8 1/8"	8		1/8"
8 1/4"	8		1/4"

### Examples:

Height of rail ..... 6-5/8"  
 Derail size ..... 7  
 Notch ties ..... 3/8"  
 Height of rail ..... 5-1/2"  
 Derail size ..... 5  
 Shim derail ..... 1/2"

Tie notched

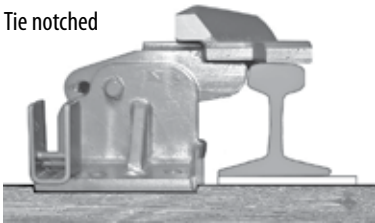

Derail shimmed

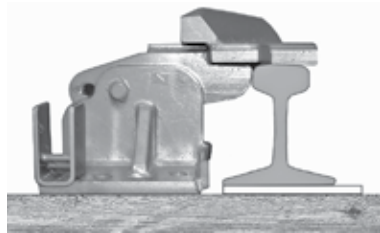
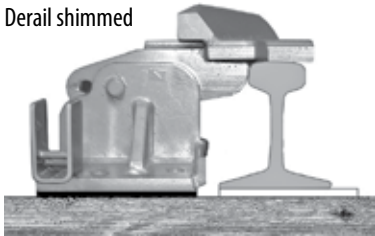

No adjustment necessary: derail base height = height of rail

**SPIKE THE DERAIL:** Install all six of the screw spikes provided.

**FINAL STEP:** Install the sign holder to connection box on derail. Holder should swing freely up and down.

## HOW TO GET A GOOD DERAIL FIT

### MEASURING HEIGHT OF RAIL



**To be effective, a derail must be correctly sized for the rail it is installed on, and adjusted in height so that the derail block (the part that swings onto the rail) lies flat on the surface of the rail.**

There are many sizes of rail to be found in industrial spur tracks. The first step to insuring a good derail fit is to carefully measure the height of the rail above the tie.

The simplest way to make this measurement is to place a 5-foot steel bar or pipe across the rails and measure up from the tie with a ruler, keeping close to the rail against which the derail will be installed. Read to the nearest 1/8".

## HOW TO GET A GOOD DERAIL FIT

### CROP THE TIE PLATES



The derail sits on two ties and must be pushed up against the rail head. The tie plates inside the rail will get in the way, so it is necessary to crop the plates close to the base of the rail. The derail base must sit flat on the ties.



Mark each tie plate about an inch away from the rail base. Use a metal-cutting power saw or a torch.

If using a saw, remove the spike on the gauge side and cut the plates.

If using a torch, you will need to remove the two tie plates from under the rail, crop them, and then reinstall them under the rail, re-spiking the outer portions of the plates.



**Do not, as a short cut, permanently remove the tie plates. They are needed to support the rail and hold to gauge.**

## HOW TO GET A GOOD DERAIL FIT

### ADJUSTING DERAIL TO RAIL HEIGHT

**The underside of the derail block must be level with the top of the rail.** It may be necessary to either notch the two ties to lower the derail, or use metal shims to lift the derail.

To lower the derail, make a series of kerf cuts in the two ties. Maximum notching depth: 3/8".

To raise the derail, use 1/4" and 1/8" Aldon steel shims. Maximum shimming height: 3/4".



**Too High.** There should be no space between derail block and top of rail.



**Too Low.** A derail block that does not lie flat will cause a failure to derail.



**Just Right.** Derail block lies flat on rail; derail base sits flat on ties.

## ATTACHING THE DERAIL CONNECTION BOX



After your hinged derail is positioned in the desired location. Place the derail connection box over the "middle" derail screw spike hole. (Shown in Picture) Insert the derail screw spike through the hole on the derail connection box and completely fasten the spike. Finish installing the remaining (5) derail screw spikes. Once your derail is securely fastened, install the derail sign to the connection box.

## ACCESSORIES



### Use Aldon® Derail Lifting Lever to

Reduce the lifting effort by 60%.

#### 4014-28

Lever for 3/4" Block

#### 4014-25

Lever for 1" Block

**Moon Sign** is a 18" diameter sign with over three times the area of the usual blue derail sign. White retro-reflective white facing and oversized DERAIL lettering on both sides. **4015-185**



Pre-Drilled  
Steel

Aldon® Derails can be padlocked in the "on-the-rail" position or "off-the-rail" position



#### 4124-97 Padlock



**Aldon® Derail Shims** for Derails w/ Pop-Up Signs

**4014-26** 1/8" thick

**4014-27** 1/4" thick

Derails w/ Manual Lift Signs

**4014-31** 1/8" thick

**4014-32** 1/4" thick



Locked: on position



Locked: off position

## OPERATION

### Aldon recommends the following procedure for hinged derails on industrial sidings:



Always lower and raise the derail sign when you remove or reinstall the derail block.

**1** Keep derail padlocked in "on position" between switching movements. Be sure sign is standing up.

The same procedures apply to Pop-up Sign style derails (not shown here).

**2** The switch crew brakeman requests the plant worker to remove the derail so the switching movement can be made. Use the Aldon® Derail Lifting Lever for easy leverage.

**3** After the switching movement is completed, the plant worker must reinstall the derail and padlock it, making sure to re-erect the derail sign. The siding is once again protected from intrusion.

**RAIL CLEARANCE:** Derail height on the rail is 3". When the derail is in the off position it is below the height of the rail.

## MAINTENANCE

1. Keep derail freshly painted in yellow gloss enamel. Besides maintaining good visibility, the glossy paint surface acts as a lubricant in the event of a derailment, easing the wheels' passage.
2. Check spike holding condition from time to time. If the ties deteriorate, replace the ties.
3. After a derailment, inspect derail for wear and tear and replace the derail on any sign of deformation.